

TODO check if TX/RX are not swapped

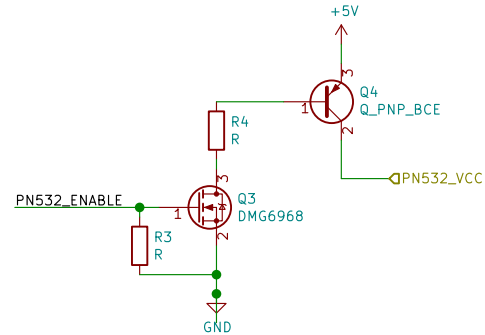

VCC is connected to strike when door is closed and bolt is out (blocking door from being open)

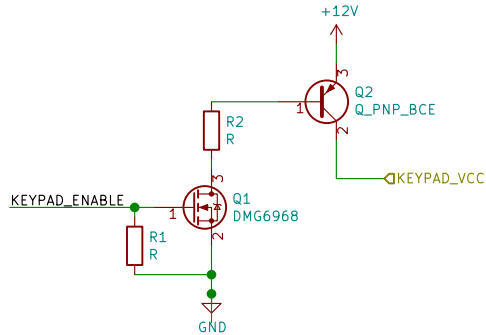
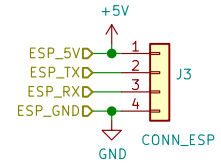